



RIGA TECHNICAL  
UNIVERSITY

**Dmitrijs Guzs**

**COST EFFECTIVE INNOVATIVE SOLUTION  
FOR TRANSMISSION CAPACITY MANAGEMENT  
IN LOW-INERTIA WEAKLY INTERCONNECTED  
POWER SYSTEMS**

Summary of the Doctoral Thesis



RTU Press  
Riga 2023

**RIGA TECHNICAL UNIVERSITY**  
Faculty of Electrical and Environmental Engineering  
Institute of Power Engineering

**Dmitrijs Guzs**

Doctoral Student of the Study Programme “Power and Electrical Engineering”

**COST EFFECTIVE INNOVATIVE SOLUTION  
FOR TRANSMISSION CAPACITY  
MANAGEMENT IN LOW-INERTIA WEAKLY  
INTERCONNECTED POWER SYSTEMS**

**Summary of the Doctoral Thesis**

Scientific supervisors  
Professor Dr. habil. sc. ing.  
ANTANS SAUĻUS SAUHATS  
Professor Dr. sc. ing.  
ANDREJS UTĀNS  
Associate Professor Dr. sc. ing.  
GATIS JUNGHĀNS

RTU Press  
Riga 2023

Guzs, D. Cost Effective Innovative Solution for Transmission Capacity Management in Low-inertia Weakly Interconnected Power Systems. Summary of the Doctoral Thesis. – Riga: RTU Press, 2023. 36 p.

Published in accordance with the decision of the Promotion Council “RTU P-05” of 26 April 2023, Minutes No. 93/23.



This research is co-funded by the Latvian Council of Science, project “Multi-functional modelling tool for the significantly altering future electricity markets and their development (SignAture)”, project No. lzp-2021/1-0227 and by the Ministry of Economics of the Republic of Latvia, project “Future-proof development of the Latvian power system in an integrated Europe (Future-Proof)”, project No. VPP-EM-INFRA-2018/1-0005, and project “Innovative smart grid technologies and their optimization (INGRIDO)”, project No. VPP-EM-INFRA-2018/1-0006.

<https://doi.org/10.7250/9789934229169>

ISBN 978-9934-22-916-9 (pdf)

# **DOCTORAL THESIS PROPOSED TO RIGA TECHNICAL UNIVERSITY FOR THE PROMOTION TO THE SCIENTIFIC DEGREE OF DOCTOR OF SCIENCE**

To be granted the scientific degree of Doctor of Science (Ph. D.), the present Doctoral Thesis has been submitted for the defence at the open meeting of RTU Promotion Council on 27 June, 2023 at 11.00 at the Faculty of Electrical and Environmental Engineering of Riga Technical University, 12 k-1 Azenes Street, Room 306.

## **OFFICIAL REVIEWERS**

Associate Professor Dr. sc. ing. Ļubova Petričenko  
Riga Technical University

Senior Researcher Dr. sc. ing. Arturas Klementavicius  
Lithuanian Energy Institute, Lithuania

Researcher Dr. sc. ing. Artjoms Obuševs  
ZHAW Zurich University of Applied Sciences, Switzerland

## **DECLARATION OF ACADEMIC INTEGRITY**

I hereby declare that the Doctoral Thesis submitted for the review to Riga Technical University for the promotion to the scientific degree of Doctor of Science (Ph. D.) is my own. I confirm that this Doctoral Thesis has not been submitted to any other university for the promotion to a scientific degree.

Dmitrijs Guzs ..... (signature)

Date: .....

The Doctoral Thesis has been written in English. It consists of an Introduction, 6 chapters, Conclusions, 31 figures, 19 tables, 3 appendices; the total number of pages is 92. The Bibliography contains 97 titles.

# CONTENTS

Introduction .....	5
1. Theoretical background and literature study .....	11
1.1. Power system inertia and inertial response .....	11
1.2. Synchronous condensers .....	13
1.3. Load shedding schemes in synchronous power systems .....	13
1.4. Wholesale day-ahead power market.....	15
1.5. Power system of the Baltic states .....	16
2. A novel load shedding scheme – concept, materials and methods, economic rationality .	18
2.1. Inertia and inertial response in real multi-machine AC power systems .....	18
2.2. The concept of the proposed novel LS scheme .....	19
2.3. Socio-economic motivation for the proposed novel LS scheme .....	20
2.4. Materials and methods for the socio-economic analysis .....	21
3. Modelling of the power system with the proposed novel load shedding scheme .....	26
3.1. Test Case Set No. 1 .....	26
3.2. Test Case Set No. 2 .....	27
3.3. The results .....	27
4. Socio-economic assessment of the effect of the proposed novel load shedding scheme.	
Historical input data. ....	28
4.1. General info and definition of study case scenarios .....	28
4.2. The results .....	29
5. Socio-economic assessment of the effect of the proposed novel load shedding scheme.	
forecasted input data.....	30
5.1. General info and definition of study case scenarios .....	30
5.2. The results .....	31
Conclusions .....	33
References .....	34

# INTRODUCTION

## Topicality of the research

With the importance of the problem of climate change being widely recognized by the global community [1] and with the need to solve this problem by reducing the carbon emissions, the energy systems of the developed countries are currently going through a major transformation. The executive goal of the forthcoming transformation is to reach net zero carbon emissions by 2050 in order to hold the 1.5 °C climate target and is called the “energy transition” [2]. This includes transformation of all energy-intensive sectors of the economies: power generation, transmission and distribution, supply and consumption of heat and fuel, transport, agriculture, households, etc. and is done by replacing fossil energy sources with carbon-neutral/renewable ones as well as by electrification. Despite the fact that the goal is unambiguously defined and the way to achieve it is transparent, it is already clear that a number of serious problems and obstacles will arise, caused by:

- massive shutdown of the existing conventional electric power generation capacity including nuclear and the urgent need to replace this capacity [2];
- tripling of the level of electric power generation of electricity by 2050 compared to today's level with renewables providing for 90 % of the total volume [2];
- intermittency of the renewable energy sources mainly driven by the weather conditions; in some regions this intermittency is additionally amplified by the reliance on cogeneration power plants driven solely by the heat demand;
- power generation structure tending from centralized to decentralized/scattered generation;
- the planned carbon net zero energy system is still supposed to stay sustainable, secure, affordable and resilient [3].

The penetration of the power systems with intermittent renewable energy sources brings a major paradigm change for the field of electric power supply. Not only are these generation sources uncontrollable, but they are also non-synchronous – i.e. they produce power without involvement of rotating electrical synchronous machines as synchronous generators.

The mentioned factors are partially self-contradicting, so the necessity to simultaneously achieve all of these leads to a complex problem, which can only be solved through global and inter-disciplinary cooperation with the participation of technology developers and manufacturers, generating companies, transmission and distribution network operators, and millions of consumers. The problem is exacerbated by the growing interconnection between various engineering infrastructures. The power supply process can be disrupted by the occurrence of malfunctions in communication systems, water supply, transport, etc. Gas supply can disrupt power supply and vice versa. On the other hand, even short-term power outages can cause huge economic losses and tragic consequences arising from the paralysis of life in cities and countries. Extremely large losses occur in cases of large-scale blackouts in power systems. Most of the large-scale blackouts observed in power systems are triggered by random events,

which lead to loss of power system stability. Therefore, it is of principal importance to maintain the stability and uninterruptedness of the power supply during the energy transition [3].

Energy transition management should be carried out with the aforementioned objectives in mind. All these problems can contain many aspects, including ability to maintain indicators of security, stability and resilience (SSR). The problem of security of energy supply includes a known issue of preventing large-scale blackouts. However, during the period of energy transition, this problem becomes especially acute, because development of intermittent RE generation can lead to a decrease in the stability of electrical networks due to a decrease in the levels of inertia of the system caused by the decommissioning of large synchronous generators and their replacement with energy sources of asynchronous nature. The inertia deficiency subsequently brings power system frequency stability problems. The possibility of major accidents cannot be completely ruled out. Additional request to development planning arises: the power system must be able to minimize the consequences of extreme weather or malicious physical or cyber-attacks. Or in another words, power system must be secure, stable and resilient.

The challenge of ensuring SSR can be divided into two interrelated tasks:

1) the task of long-term energy SSR, which is mainly associated with investments to maintain the energy balance in accordance with long-term plans for economic carbon net zero development;

2) the task of ensuring short-term SSR, focused on the ability to quickly respond to sudden deviations in the balance of generation and demand for electricity.

The issue of significant decrease of inertia levels in synchronous power systems has become a widely acknowledged issue concerning even power systems/synchronous areas with historically sufficient inertia levels and stability reserves, such as ENTSO-E and Nordic synchronous power systems [4], [5]. The expected decline in the system inertia is expected to worsen the frequency stability of the power systems and to amplify the defined SSR challenges forcing the power system operators to seek countermeasures and to redefine system operation philosophies. This is especially true for smaller/islanded synchronous power systems such as Ireland or the Baltic states operating in an island mode after their desynchronization from the UPS/IPS power system in 2025 [6].

One of the most popular and discussed measures to counteract the decrease of the share of synchronous generators and power grids, and thus the decrease in the inertia level, is introduction of synchronous condensers (SC) into the power system [7]–[10]. The well-proven and known technology of SC relieves power system operators and helps to maintain sufficient inertia and short-circuit ratio levels independent of the dispatch pattern of the power generators. With the decreasing size of a power system, the introduction of SC increases in importance for the frequency stability of the power system.

The main topic of the Thesis is the novel usage of a SC as an active power sensor to trigger rapid load shedding (LS) in order to quickly stabilize power system frequency in low-inertia power system conditions. As very well suited for islanded/smaller power systems this approach is to be proved to be extremely well suited for the Baltic synchronous power system operating in an island mode after its desynchronization from the UPS/IPS power system. Implementation

of the proposed solution has also a great fiscal potential to the socio-economic welfare (SEW) of the users of the Baltic power grid. Demonstrating the positive technical and financial gains of the proposed LS scheme with SC as a frequency sensor is going to be the main contribution of the Doctoral Thesis.

No other literature is known to describe the scheme proposed in the Thesis. The Thesis is therefore assumed to propose a unique solution to a known and well-described power system issue.

This work fits into the international research topic of power system frequency stability.

## **The hypothesis, objective and tasks of the Thesis**

The hypothesis of the Thesis: A load-shedding scheme based on the usage of SC as a frequency sensor substantially improves the frequency stability and increases the SEW for the grid users in a low-inertia power system.

The objective of the Thesis: To prove that a load-shedding scheme based on the usage of SC as a frequency sensor has a major positive technical and fiscal effect on the Baltic synchronous power system operating in an island mode after its desynchronization from the UPS/IPS power system.

The tasks of the Thesis:

- 1) introduce and describe theoretical and practical aspects of a novel LS scheme using a SC as a frequency sensor;
- 2) through power grid simulations prove that the described LS scheme improves the frequency stability;
- 3) through power market simulations and analysis prove that the described LS scheme has a major fiscal effect on the Baltic synchronous power system operating in an island mode after its desynchronization from the UPS/IPS power system.

## **Research methods and tools**

1. For dynamic power system frequency simulations, the SIEMENS PSSE ver. 34 grid simulation software was used (under the license provided by the Latvian TSO company *Augstsprieguma Tīkls*).
2. For power system transient stability simulations ETAP 12.5 grid simulation software was used (under the license provided by Riga Technical University).
3. The SEW analysis were conducted using the EUPHEMIA algorithm simulation tool Simulation Facility (under the license provided by the Latvian TSO company *Augstsprieguma Tīkls*).



## Scientific novelty

The scientific novelty of the research presented in the Thesis can be summarized as follows:

1. A unique and novel LS scheme based on usage of SC as a frequency sensor has been developed.
2. Dynamic frequency stability simulations have been done of an islanded low-inertia synchronous power system with SC present, with and without the proposed novel LS scheme.
3. SEW simulations/analyses have been done showing the financial effect of the proposed novel LS scheme for an islanded low-inertia synchronous power system.

## Practical significance of the research

The research conducted during the development of the Thesis as well as its results have contributed to a number of research projects:

- The Latvian Council of Science project “*Management and Operation of an Intelligent Power System (I-POWER)*” (2018–2021);
- National Research Programme “*Energy*” project “*Innovative smart grid technologies and their optimization (INGRIDO)*” (2018–2021);
- National Research Programme “*Energy*” project “*Future-proof development of the Latvian power system in an integrated Europe (FutureProof)*” (2018–2021).

## Author’s personal contribution

The idea and the concept of a LS scheme based on the usage of SC as a frequency sensor was developed together with Professor A. Sauhats.

The work on proving the concept to be effective and technically viable was carried through a series of dynamic frequency stability simulations of the islanded Baltic power system in the SIEMENS PSSE ver. 34 grid simulation software. These simulations required a viable Baltic grid model; the work on the grid model and the simulations were carried out in close cooperation with M. Sc. J. Siliņēvičs (*AS Augstsprieguma Tīkls*).

The analysis of the SEW contribution in the case of applying the proposed LS scheme in the islanded Baltic power system was carried out by:

- a socio-economic welfare simulation using the EUPHEMIA algorithm simulation tool Simulation Facility in close cooperation with Dr. sc. ing. A. Ļvovs and Dr. sc. ing. G. Junghāns (both from company *Augstsprieguma Tīkls*);
- a socio-economic welfare simulation using the Riga Technical University in-house simulation tool in close cooperation with Dr. sc. ing. R. Petričenko and Professor A. Sauhats.

## Approbation of the results

The research results included in the Doctoral Thesis have been presented in the following international scientific conferences/competitions:

1. MEDPOWER 2020 – Mediterranean Conference on Power Generation, Transmission, Distribution and Energy Conversion, November 9–12, 2020, Paphos, Cyprus.
2. 61th International Scientific Conference on Power and Electrical Engineering of Riga Technical University (RTUCON), November 5–7, 2020, Riga, Latvia.
3. 31st European Safety and Reliability Conference, ESREL 2021, September 19–23, 2021, Angers, France.
4. 60th ESReDA Seminar: Advances in Modelling to Improve Network Resilience, May 4–5, 2022, Grenoble, France.
5. 2023 IEEE PES Grid Edge Technologies Conference, Ph.D. Dissertation Challenge, April 10–13, 2023, San Diego, U.S.A.

(<https://drive.google.com/file/d/1IRCGOdnmsmj3w5RGrK--LSAmUKXlakaG/view?usp=sharing>)

The results included in the Thesis have been published in the following peer-reviewed scientific publications (indexing in Scopus/Web of Science (WoS) indicated in parenthesis):

1. **Guzs D.**, Utans, A., Sauhats, A., Junghans, G., Silinevics, J. “Resilience of the Baltic power system when operating in island mode”, 2020 IEEE 61th International Scientific Conference on Power and Electrical Engineering of Riga Technical University (RTUCON), Riga, Latvia, 2020, pp. 1–6, DOI: 10.1109/RTUCON51174.2020.9316616.
2. Sauhats A., Utans A., Silinevics J., Junghans G., **Guzs D.**, “Enhancing power system frequency with a novel load shedding method including monitoring of synchronous condensers’ power injections”, 2021 Energies, 14 (5), art. no. 1490, DOI: 10.3390/en14051490
3. **Guzs D.**, Utans A., Sauhats A., “Evaluation of the resilience of the Baltic power system when operating in island mode”, Proceedings of the 31st European Safety and Reliability Conference, ESREL 2021, pp. 1876–1883, DOI: 10.3850/978-981-18-2016-8\_056-cd
4. Utans A., Sauhats A., Zemite L., **Guzs D.** “Improving Power System Frequency Response with a Novel Load Shedding Method”, 60th ESReDA Seminar: Advances in Modelling to Improve Network Resilience, France, Grenoble, May 4-5, 2022. Grenoble, France, pp. 1–6.
5. **Guzs D.**, Utans, A., Sauhats, A., Junghans, G. and J. Silinevics, “Resilience of the Baltic Power System When Operating in Island Mode”, IEEE Transactions on Industry Applications, vol. 58, no. 3, pp. 3175–3183, May-June 2022, DOI: 10.1109/TIA.2022.3152714.

## Volume and structure of the Thesis

The Doctoral Thesis is written in English. It consists of introduction, six main chapters, 21 subchapters, 21 sections, conclusions and a bibliography with 97 references. The Thesis also contains 31 figures and 19 tables. The volume of the Thesis is 92 pages.

Chapter 1 is dedicated to theory and background information on power system inertia, frequency, synchronous condensers, load shedding schemes, and the existing situation in the Baltic power system, as well as the expected future developments regarding the synchronization of Baltics to the ENTSO-E grid in 2025.

Chapter 2 proposes the concept and methods for a novel load shedding scheme using synchronous condensers as frequency/ROCOF sensors. Further, the methods for evaluating the socio-economic welfare gains of introducing this novel load shedding scheme are extensively described: both for the Euphemia model (historic data for year 2020) and for the in-house RTU power market model using forecast data for the future years 2030–2050.

Chapter 3 describes a set of simulation test cases where frequency stability of the modelled Baltic power system is assessed during large loss-of-generation contingencies. The two different test case sets use two different models of the Baltics, but both give comprehensive results on the possible effect of the proposed load shedding scheme on the system frequency.

Chapter 4 describes a set of test cases where the potential effect of the proposed load shedding scheme on the socio-economic welfare gains is studied on a model using historical Baltic power market data for the year 2020.

Chapter 5 describes a set of test cases where the potential effect of the proposed load shedding scheme on the socio-economic welfare gains is studied on a model using forecasted Baltic power market data for the years 2030, 2040, and 2050.

Chapter 6 contains the discussion of the results of all the simulations, both for the frequency stability and for the socio-economic welfare.

Finally, the overall conclusions are made in the Conclusions.

# 1. THEORETICAL BACKGROUND AND LITERATURE STUDY

## 1.1. Power system inertia and inertial response

Frequency stability of alternating current (AC) power systems, together with the voltage and the transient angular stabilities, is a cornerstone of secure and reliable operation of any modern power system. System frequency in a power system must be kept at the nominal value of 50/60 Hz (depending on the region). The system operator must ensure that any disturbance or frequency deviation in the controlled AC power grid is met with adequate and timely countermeasures which ensure always keeping the frequency deviations within an acceptable range. The fundamental relation between the active power balance and the frequency of the power system is derived from the swing equation (see Eq. (1.1)) [11].

$$\frac{df}{dt} = \Delta P \frac{f_{syn}}{2H_{tot}} \quad (1.1)$$

The swing equation states that the rate of change of the system frequency (ROCOF) is directly proportional to the instant active power imbalance  $\Delta P$  of the system and is inverse proportional to the total system inertia  $H_{tot}$ . This means that in case of an active power imbalance the system frequency will start to fall with a ROCOF proportional to the amount of active power lost and inverse proportional to the system inertia. In a real multi-machine power system, the system frequency at this very moment of the transient power imbalance oscillations alters from being a global to a local parameter [12] and Eq. (1.1) starts to describe the behavior of each generator separately. In this situation every synchronous electrical machine connected to the power grid will yield an inertial response – that is, it will react locally to this negative ROCOF according to the same Eq. (1.1) by injecting active electrical power obtained from transforming the mechanical power of its rotor (slowing the rotor down). This inertial response will restrict the fall of the frequency allowing to win time for other frequency regulating mechanisms to be activated in order to stabilize the system frequency. The different responses in the described generator outage situation are well depicted in Fig. 1.1. It clearly shows the importance of the inertial response of the synchronous electrical machines in the power grid. Without the inertial response the system frequency would have fallen rapidly below an acceptable threshold causing cascading disconnections of the synchronous generators in the power system and thus a system-wide blackout.

The importance of the inertial response and the system inertia for the frequency stability becomes especially visible with the ongoing trend of decommissioning of conventional power sources and replacement of these with renewable and non-synchronous power sources. This leads to a decrease in the overall power system inertia levels and thus to larger frequency deviations/ROCOF, as indicated by Eq. (1.1), during incidents causing more frequency reserves to be consumed or in some cases – even load shedding (LS) schemes – to be activated. This

forces system operators to look for alternative measures to sustain system inertia levels, for example, installation of synchronous condensers (SC) or synthetic inertia units [5], [13].

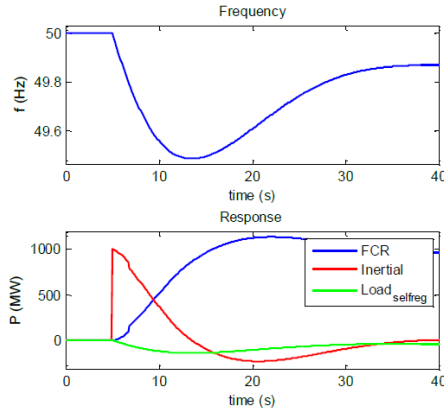

Fig. 1.1. Frequency, inertial, and FCR response to a generator outage [5].

### 1.1.1. Challenges of timely detection of ROCOF

The instant reaction time of the inertial response is a consequence of the “organicity” of the reaction of rotors in synchronous generators to the fluctuations in the grid (stator) frequency originating from the electromagnetic coupling between the rotor and the stator of a synchronous machine. Other possible corrective measures for rapid power system frequency stabilization such as synthetic inertia, fast frequency reserves or any advanced LS scheme have no other choice as to use ROCOF as an input exactly due to the reason of rapidity of the ROCOF response and its unwavering connection with the active power balance of the power system. But as the above-mentioned frequency corrective measures lack the synchronous nature of a synchronous machine, these measures have to rely on a ROCOF measurement instead of a natural  $\Delta P$ -ROCOF response. Securing both reliable and rapid ROCOF measurements is a challenging task.

The most common technique for ROCOF measurements is the measurement of time period between zero crossings of the voltage sinusoidal: the time period between zero crossings is translated into frequency and subsequent zero-crossing time periods are continuously compared to each other in order to detect the ROCOF. This technique is not resilient against grid voltage transients, as these introduce phase shift in the zero crossings of the voltage sinusoidal and can therefore disrupt frequency/ROCOF measurement quality (see Fig. 1.2). The apparent way of avoiding the transient induced measurement disruptions, that is, to distinguish between a real ROCOF incident and a grid fault or switching event induced transients, is to measure the zero crossing for more cycles thus ensuring the quality of the frequency/ROCOF measurement. Typical measuring window for a ROCOF measurement therefore is 2–100 cycles (40 ms – 2 s) [13]. In addition, a time delay of typically 50–500 ms is also introduced in order to avoid possible transients in the signal [13]. These numbers give us a very minimum time of no less

than 100 ms for a ROCOF measurement – this measurement will be of low quality. Literature indicates 500 ms (0.5 s) to be an appropriate measurement period for a reliable ROCOF measurement [13]. Another problem with ROCOF measurements is the damped frequency swings from synchronous generators and their control systems following a power imbalance incident in a real multi-machine AC power system [13].

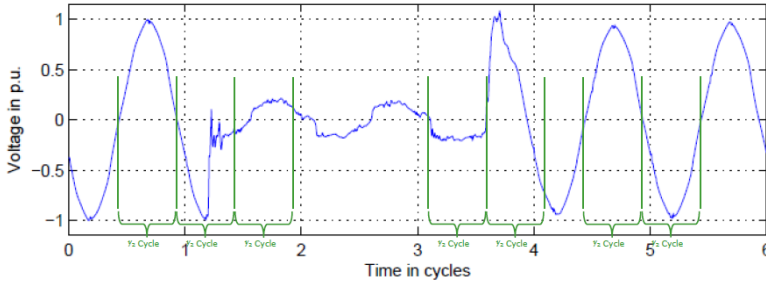

Fig. 1.2. Zero crossings during a voltage transient [13].

## 1.2. Synchronous condensers

Synchronous condenser (SC) is a synchronous electrical machine which is not connected to any prime mover such as a steam or a hydro turbine. SC is neither a generator nor a motor, as it does not produce or consume active power but a synchronous electrical machine idling synchronously locked with the rotating electric field of the power grid. A SC has all qualities of a classic synchronous generator, similar design and behavior. SC provides rotational inertia, which can be additionally increased by means of installing a flywheel on the SC rotor shaft [14]. The inertia contribution of SC is a key feature considering the massive developments of renewable and non-synchronous sources and loss of system inertia. In literature installation of SC is considered to be the best suitable technology for mitigating the reduction of power system inertia [13] and the ability of SC to limit the negative ROCOF of the system frequency during frequency incidents is clearly shown.

## 1.3. Load shedding schemes in synchronous power systems

### 1.3.1. Traditional under-frequency load shedding (UFLS)

Under-frequency load shedding (UFLS) is a classic and commonly accepted measure used in AC power systems to counteract a potential frequency collapse following a serious loss-of-generation incidents and instant imbalance between generated and consumed power. The UFLS is typically triggered when the activation of available frequency reserves does not provide a sufficient frequency stabilization. UFLS is usually defined by a list of loads with matching frequency thresholds, which are disconnected from the grid by frequency relays when the grid frequency reaches any of the predetermined thresholds in the list. The use of UFLS obeys the Eq. (1.1) – it reduces the  $\Delta P$  and thus improves the ROCOF of the power system, or even

switches the ROCOF from negative to positive contributing to stabilize the system frequency. The loads disconnected by UFLS are typically the whole MV side(s) of a HV/MV substation(s) [15]. The schematic logic principle of UFLS can be seen in Fig. 1.3.

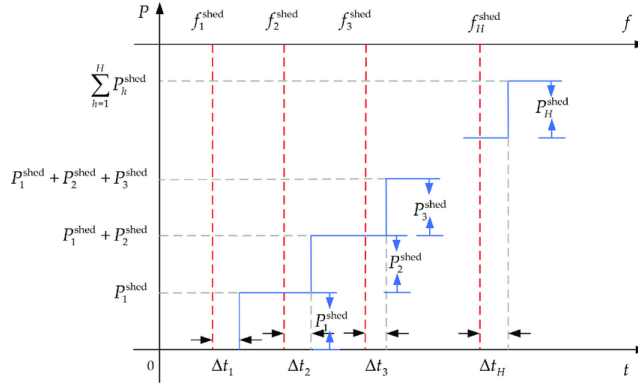

Fig. 1.3. Logical principle of traditional UFLS [16].

### 1.3.2. Economic rationality of UFLS schemes

The fundamental need for a UFLS scheme is dictated by the economic rationality behind the historically increasing size of generation units in the power systems. The historical growth of power generation units progressed in order to reduce the cost per unit of generated electrical energy, as increase in size comes with an increase in economic efficiency of the production – a fundamental postulate of basic economic theory. Increased generator size also brings larger potential loss-of-generation incidents and subsequent larger drops in the system frequency. UFLS enables power system to include large generation assets, as larger loss-of-generation incidents can be tolerated with the UFLS present, thus UFLS scheme contributes to reduce the overall costs per unit of electrical energy. Indeed, a power system can also be built without a LS scheme, but this kind of system will remain economically suboptimal due to restricted maximum size of the generation units or an increased need for reserve capacity [17]. The economical suboptimality of a power system due to restricted maximum size of generation assets or sources is also the central topic of the Thesis considered in the context of the expected developments in the Baltic power system after year 2025. The assessment of the socioeconomic costs expected as a result of this suboptimality is one of the goals of the Thesis.

The literature study has shown that despite a rich selection of technical papers on UFLS and its variations almost no attention is devoted to the economic assessment of the impact of UFLS schemes. This can be explained by the fact that UFLS is a last-resort measure to avoid a full frequency collapse/blackout and therefore is activated extremely seldom or because LS is anyway a more preferable alternative to a blackout and hence the costs of LS are to be considered to be justified. Some scarce information on the cost of energy not served (ENS) of shed loads can be gained from authors from developing countries where LS is not a frequency stability countermeasure but rather a common measure to balance generation and load in an

environment with chronic generation capacity scarcity. Cost of disconnected load always has a value – whether it is the value of lost load (VOLL) or value of ENS and differs for different types of loads (for example, industrial, commercial or residential) and also from country to country. The available literature provides no traces of economic assessment of costs and benefits related to the presence of UFLS versus absence of UFLS in power systems.

When a LS scheme is activated, loads are disconnected from the grid. The negative effect of load disconnection has been quantified in monetary terms by estimating the VOLL. The author in [18] provides a good overview of the VOLL-values for different countries/regions in the EU and for different consumer types.

### **1.4. Wholesale day-ahead power market**

The wholesale day-ahead power markets in the European Union (EU) are all based on the price formation logic called marginal price logic. The power exchanges, also known as Nominated Electricity Market Operators (NEMOs), daily receive sell and buy bids from the respective generators and consumers in their market zone for each hour of the next day. NEMOs aggregate those bids and thus create a single cumulative row of bids for generation and consumption for each hour. A cumulative generation bid row grouped by the rising marginal price of the submitted bids is called a “merit-order”, as it orders the available submitted generation at the price for which the sellers/generators are willing to sell their power for [19]. When for a given hour the consumption and generation cumulative bid curves intersect, as seen in Fig. 1.4, the market cross is conceived. This market cross reveals what cumulative volume the consumers are ready to consume at a certain marginal price at which the generators are ready to sell their generated power. The power price given by the market cross is the price of the last bids in both cumulative bid curves; this means the market cross price is the one all of the activated generation bids will receive (even if some of these have bidden at a lower price), hence the name of marginal price logic. The same principle applies to the consumers – all of the consumers will pay the same marginal price for the power even if some of the consumption bids were priced higher. The principle and logic of marginal power price provides a fair balance between the interests of power consumers and producers. The socioeconomic welfare provided by the marginal price power market model is the net sum of the extra income the generators receive (producer surplus) and the extra savings consumers harvest in comparison to what they were willing to buy the power for according to their bids (consumer surplus) [20]. The surplus of consumers and generators (producers) is illustrated by the red and blue areas in Fig. 1.4.

Since the EU comprises many countries and market zones, all of these have to be interconnected in order to achieve a pan-European market coupling and to enable cross-border power flows in accordance to the goal of maximization of the total socioeconomic welfare, which is the sum of the consumer and producer surpluses. This common EU day-ahead power market coupling solution uses the Single Price Coupling Algorithm called Euphemia. Public description of Euphemia can be accessed in [21]. Euphemia solves the market coupling optimization problem consisting of supply and demand bids, considering limitations – cross-border capacities between bidding zone borders and allocation constraints. The goal of



optimization is to maximize the total socioeconomic welfare of the whole interconnected area and not a single market zone. This means that a net socioeconomic welfare of a single market zone can even theoretically be reduced in order to increase the net total welfare of the interconnected area. As already mentioned, the net socioeconomic welfare consists of the sum of consumer and producer surpluses, as shown in Fig. 1.4.

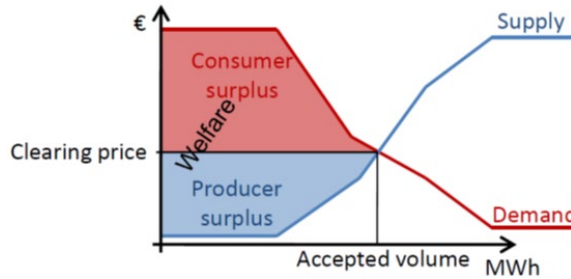

Fig. 1.4. Price cross of the power supply and demand curves, graphic definition of socioeconomic welfare [22].

## 1.5. Power system of the Baltic states

### 1.5.1. General information and planned ENTSO-E synchronization

Power transmission grid of the Baltic states is a meshed, interconnected 330 kV grid with a peak load of ca. 4000 MW [23]. It has a strong synchronous interconnection with the Unified Power System of Russia (UPS) synchronous power system and has asynchronous HVDC connections to both Finland, Sweden and Poland (see Fig. 1.5). The maximum exchange capacity of all interconnections to the Baltics is around 4700 MW [17], which makes it theoretically possible to supply the peak load of Baltic power grid with imports alone. Main generation assets in the Baltic power grid comprise thermal oil-shale and wind power generation in Estonia, large river hydro power plants plus a major gas-fired power plant (Riga TEC2) in Latvia and a combination of wind power, small/medium sized CHPs, a major pump-storage and a major gas-fired power plant in Lithuania. The Baltic power grid is heavily relying on imported power with the total import in 2019 comprising 47.6 % of the total consumption, with largest net power exporters to the Baltics in 2019 being Belarus, Finland, and Sweden [24]. The interconnection with UPS today provides the Baltic power system with vast frequency and inertia reserves.

A political decision has been taken to desynchronize the Baltic states from the UPS power system and to synchronously connect it with the European Network of Transmission System Operators (ENTSO-E) power grid in 2025 [6]. This plan proposes the disconnection of the nine 330 kV transmission lines synchronously interconnecting the Baltic and the UPS power systems. These lines have a total thermal capacity of ca. 9000 MW and a nominal transmission capacity of ca. 2500 MW (see Fig. 1.5). After the disconnection itself, a synchronous connection between the Baltic and the ENTSO-E (Poland) power systems is to be established through a

single double-circuit 400 kV synchronous interconnection on the Lithuania–Poland border with thermal capacity of ca. 2000 MW [17].

In situations when this synchronous interconnector between the Baltics and Poland goes out on a planned or an unplanned outage, the result will be the operation of the Baltic states’ power grid in an island mode. During this mode of operation, the Baltic power system is only to rely on its own inertia and frequency reserves, which are radically lower than today’s available inertia and frequency reserves provided by the UPS power grid. The island mode of operation is to introduce major challenges to the operational frequency stability of the Baltic power grid. The main and fundamental challenge the Baltic power system will face is the vast size of the generation/HVDC units compared to the overall size of the power system in the island mode. Today there is a lack of ability of the existing conventional power plants to provide a rapid frequency support – so much needed in the radically different island mode expected in the Baltic power system after the desynchronization.

Another development to impact the inertia level of the Baltic power system is the expected rise in intermittent non-synchronous renewable generation capacity. Around 4000 MW of wind generation capacity is planned in the Baltic states up to year 2034 according to [25]. Separate national renewable energy targets in the scope of the EU 2030 Climate & Energy Framework [26] indicate a sharp rise of share of renewable generation. This implies that the total inertia level of the Baltic power system is expected to decline.

To mitigate these developments and to safeguard frequency stability of the Baltic power grid, the European and Baltic TSOs have agreed to implement a range of measures. One of these is to invest in three synchronous condensers (SC) rated ca. 305 MVA for each Baltic TSO each – totaling nine synchronous condensers planned in the Baltic power grid by 2025 [17].

Another planned measure is to install battery storage systems for rapid FCR provision [27], [17], a move anticipated in literature earlier and even methods provided for implementation [28].

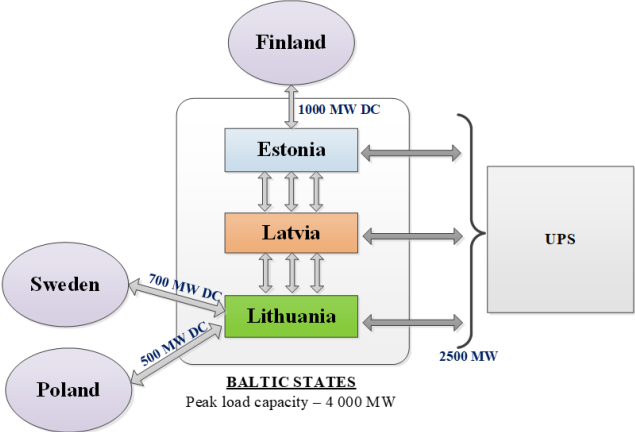

Fig. 1.5. Schematic power system interconnection of the Baltic states.

## 2. A NOVEL LOAD SHEDDING SCHEME – CONCEPT, MATERIALS AND METHODS, ECONOMIC RATIONALITY

### 2.1. Inertia and inertial response in real multi-machine AC power systems

An unexpected disconnection of a large generator in the power system causes a transition to a new state – in particular, the rotation frequency of synchronous generators, synchronous condensers and motors is subject to change (decreases). In the process of decelerating of rotating masses of the elements of the power system, the kinetic energy accumulated in them is transformed into electric energy and injected into the electrical network. As a result of this injection (inertial response) the balance of generated and consumed electrical energy is maintained even during the transient process. Within a few seconds delay after disturbance, generator's governors, in response to a decrease in frequency, start to react on the frequency decline trying to restore the frequency rated value (primary frequency control). Additionally, diminishing of the frequency causes a decrease in the power consumption of the frequency dependent load. However, the initial period of the considered transient process is mainly determined by the disconnected generator with active power  $\Delta P$  at the beginning of the process and the inertia of the system. In such case the impact of primary frequency control and the decrease in the power consumption can be neglected. Consequently, we can assert that the volume of the disconnected power  $\Delta P$  at the very beginning of the process prior to primary frequency control is compensated by the injection of the active power by each element of the power system possessing inertia:

$$\Delta P = \sum_{a=1}^S \Delta P_{SC\_a} + \sum_{b=1}^G \Delta P_{G\_b} + \sum_{c=1}^L \Delta P_{L\_c}, \quad \forall a \in S, \forall b \in G, \forall c \in L, \quad (2.1)$$

where  $\Delta P_{SC\_a}$ ,  $\Delta P_{G\_b}$  and  $\Delta P_{L\_c}$  are active power injections of every synchronous condenser, synchronous generator and frequency dependent load (for example, electric motors) present in the power grid;  $S$ ,  $G$ ,  $L$  are the total numbers of synchronous condensers, synchronous generators and frequency dependent loads in the power grid. To stop the change in frequency, it is enough to restore the balance of generation and consumption by disconnecting, for example, a load equal to  $\Delta P$ . Estimates of the volume of this load can be carried out on the basis of measuring all  $\Delta P$ 's included in Eq. (2.1). However, in real power systems, due to the large number of elements, this path is unacceptable. The problem can be simplified by assuming that Eq. (2.1) can be represented as

$$\Delta P = K_r * \sum_{a=1}^S \Delta P_{SC\_a}, \quad (2.2)$$

where  $K_r = \frac{\sum_{b=1}^G \Delta P_{G\_b} + \sum_{c=1}^L \Delta P_{L\_c}}{\sum_{a=1}^S \Delta P_{SC\_a}} + 1$ .

If the coefficient  $K_r$  is known, to estimate  $\Delta P$ , it is sufficient to measure the power injections of all synchronous condensers  $\sum \Delta P_{SC}$ . In real life, the coefficient  $K_r$  is not a constant value, it depends on the operating mode of the power system, its topology and also of the total system inertia level. However, in any case, we can assert that the measured  $\sum \Delta P_{SC}$  can be taken as the basis for disconnecting/shedding the load for frequency stabilization. This load shed must be in a volume not less than  $\sum \Delta P_{SC}$ . Such disconnection, as will be shown below, can significantly increase the efficiency of systems where the main source of inertia are synchronous condensers. Equation (2.2) will give an opportunity to rapidly predict the fall in the system frequency and therefore form the basis of the decision to initiate a fast triggering of the proposed LS scheme. Monitoring of SCs only is achievable in practice and can be used as a basis for power imbalance and system frequency prediction. The implementation of such a concept would require usage of a Wide Area Measurement System and dedicated measurement units/terminals.

## 2.2. The concept of the proposed novel LS scheme

The simulations conducted for the Baltic grid in island mode [29] have shown that after shortfall of a major generation unit in the Baltics, a ROCOF of 0.75 Hz/s (0–500 ms) is observed and the typical classic first UFLS threshold of 49 Hz is reached in approx. 1.75 s from the moment of the contingency. That means that if an alternative UFLS method is to bring added value to the Baltic power grid, it should provide triggering considerably faster than 1.75 s. In [30] it is stated that a fast response for frequency stabilization should be activated faster than 800 ms in situations with ROCOF of around 1 Hz/s, and load shedding can be considered as a type of frequency stabilization measure.

The Thesis proposes a novel LS concept using a principle of much faster triggering of LS than the conventional UFLS. This novel principle will allow to trigger LS not later than 100 ms from the moment of the contingency without usage of either frequency or ROCOF measurements. The principle of this approach is predictive and based on the monitoring of the active power injections of the SCs present in the power system. The rationale is as follows: active power injection of a SC in an AC power system contains information on the ROCOF of the system and according to Eq. (1.1), that corresponds to an instantaneous disbalance in the active power parity in the power system. SC active power injections can therefore be used as a set off for rapid LS activation. The schematic representation of the proposed novel LS principle is seen in Fig. 2.1.

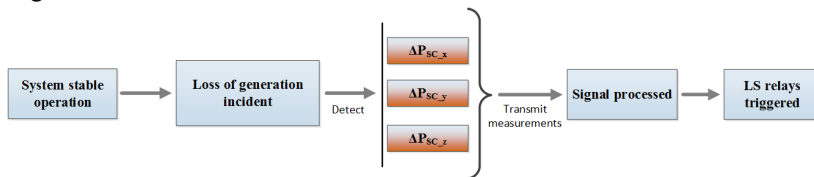

Fig. 2.1. Schematic of the proposed novel LS principle.

### 2.2.1. Technical details of the proposed novel LS scheme implementation

Measurements of active and reactive components of the vectors of currents and voltages,  $U_a$ ,  $U_r$  and  $I_a$ ,  $I_r$ , must be collected. Their values at times  $t$  and  $t + 1$  allow to calculate the total active power injection based on elementary arithmetic operations according to Eq. (2.3):

$$\Delta P(t+1) = U_{a(t+1)}I_{a(t+1)} + U_{r(t+1)}I_{r(t+1)} - (U_{a(t)}I_{a(t)} + U_{r(t)}I_{r(t)}). \quad (2.3)$$

A potential scheme for the SC measurement arrangement can be seen in Fig. 2.2.

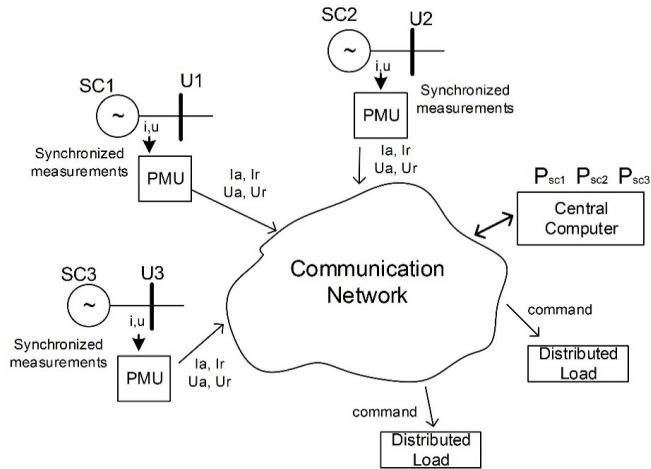

Fig. 2.2. Potential measurement/command arrangement for the proposed LS scheme.

The voltage and current phasors are collected from PMUs as shown in Fig. 2.2, and to calculate the active power injection of the SC, the Eq. (2.3) is used. Load shedding sequence is triggered when a SC active power injection exceeds a certain minimum allowed imbalance value. At next step the amount of load to be shed is calculated. The final step is sending tripping commands to appropriate relays/IEDs according to the calculated required shed load.

### 2.3. Socio-economic motivation for the proposed novel LS scheme

Activation of LS schemes has traditionally been considered as measure triggered only by critical grid situations (mostly frequency contingencies), a measure subjected purely to technical considerations and not to any sort of economic or socio-economic examination. The Thesis will have a different view on the usage of LS, a view where LS is examined also from a socio-economic angle. This kind of ultra-rapid LS can provide TSOs with possibilities of introducing less stringent N-1 grid security criteria (both for generation and transmission assets) and increasing transmission capacities between bidding zones/market areas, thus potentially lowering the socio-economic costs and increasing socio-economic welfare in these areas. In [31] a methodology is provided for the assessment of the socio-economic costs connected to

the transmission capacities and the interruption costs similar to those arising from the LS scheme activation. The methodology used in the Thesis will be similar to the one used in [31] but adjusted for the details of the case study of the Thesis, which is the power system of the Baltic states after the planned synchronization with the ENTSO-E area in 2025.

As mentioned, after the synchronization with the ENTSO-E in 2025, the power system of the Baltics will have only one double-circuit 400 kV synchronous interconnection with the rest of the ENTSO-E (Poland). The available transmission capacity on this AC link is planned to be only 100 MW [17]. Any common-mode outage of this line will lead to an islanding of the Baltic power system, a mode of operation with major challenges to the frequency stability of the Baltic power grid. The expected reduction of the system inertia levels due to the rising share of non-synchronous renewable generation capacity in the Baltics additionally severely worsens the frequency stability outlook of the post-2025 Baltic power system in the island mode.

In addition to the already mentioned installation of the SC in the Baltic power system, another mitigation is planned for the island mode of operation – market restrictions. The following market-based actions are to be instantly carried out in the Baltic power grid in the case of the event of island operation [17]:

- immediate reduction of the transmission capacities on the importing HVDC connections down to max. 400 MW import capacity;
- following redispatch of the power plants/activation of reserves as a result of these HVDC capacity restrictions.

These restrictions are to ensure that a single power source delivers no more than 400 MW of active power into the Baltic power grid. 400 MW is an amount the Baltic TSOs consider to be a maximum safe limit for an outage incident the Baltic power system in island mode can withstand [17]. The restrictions are to be upheld as long as the islanding of the Baltic power system is in place. These island mode market restrictions of the import capacity into the Baltics are expected to result into a major reduction of the socio-economic welfare, this mainly due to a lower supply volume available for the power market due to import constraints.

Power system of the Baltic states post year 2025 will be in a unique situation not present anywhere else in the world: a fully-sized AC power system synchronized with another large power system but always in the standby to go into island mode of operation. This implies also a more probable activation of the LS scheme in the Baltic power system. Thus, the proposed novel LS concept can result in the unnecessary of implementation of the mentioned market restrictions (single power source delivers no more than 400 MW) during an event of islanding of the Baltic power system and socio-economic savings.

## **2.4. Materials and methods for the socio-economic analysis**

To investigate the proposed hypothesis about the increase of the SEW due to the proposed novel LS scheme, possible island operation modes of the Baltic power system shall be estimated, as well as the changes of socio-economic welfare, the gains from congestion income, the costs of power system reserve activation shall be analyzed and the consumer losses due to the load shedding shall be evaluated.

Island operation mode of the Baltic power system occurs in cases when there is an outage of the only synchronous interconnector between the Baltic states and the ENTSO-E area. One needs therefore to know how often and how long the Baltic power systems would operate in an isolated mode. To estimate this, an analysis of AC transmission line outage statistics is needed.

The reduction of socio-economic welfare – or the loss to the wholesale power market – occurs due to limited trading capacities on bidding-zone borders, which could be introduced during the island operation mode. Simultaneously the TSOs are gaining increasing congestion income. During the first hours of island mode operation – from the moment of the occurrence of the island operation mode – the reserves are activated and bring additional costs to the TSOs. In addition, consumer losses due to the disconnections (VOLL/ENS) also have to be considered.

#### **2.4.1. Statistics of AC lines outages and major incidents**

Today's LitPol HVDC link is the future-to-be AC connection between the Baltics and the ENTSO-E grid. Based on the fact that this line is relatively new and has been in operation for a relatively short period of time, the usage of available outage data, especially for common mode double circuit outages, taken directly from the LitPol link statistical data and extrapolated onto the future could be questionable. Therefore, usage of more credible data for the statistics of AC lines' outages is required and is by us taken from various sources regarding the outages of AC lines with voltages from 330 kV till 500 kV. Data on the number of outages per 100 km of single-circuit AC line per year, as well as data on duration of outages (where available) has been gathered, as well as data on the outage probability ratio between single and double circuit (common mode) AC lines of the same voltage [32]– [37]. This particular ratio is meant to be applied on the mentioned AC line statistics to deliver a universal number of common mode outage probability per 100 km of double-circuit line per year. These results are followingly applied to the LitPol Link by taking into account the length of the whole link assumed in this paper. As a result, there we get an estimated number for outages per year of the synchronous link between the Baltic and ENTSO-E power systems and also the expected average outage duration, representing the expected regularity of the island operation mode and its duration on a yearly basis. Statistical data on the major incidents on other HVDC links are gathered from the NordPool UMMs [38].

#### **2.4.2. Methods for the test case power market/power system simulations and the subsequent calculation of the SEW**

To estimate the potential monetary gain of the proposed LS scheme, first of all, changes in the socio-economic welfare of the Baltic wholesale electricity market/power system should be calculated for the cases without proposed LS scheme (and therefore – with restrictions to the cross-border transmission capacity) and then – with the proposed LS scheme (and hence with no cross-border capacity restrictions).

In order to assess this potential reduction of the socio-economic welfare for the Baltic power system, two different test case power market simulations will be conducted for this Doctoral Thesis:

- a simulation with historical data for 2020 using the simulation facility tool;
- a simulation set with forecasted data for 2030, 2040, and 2050 using an RTU in-house-developed market simulation environment.

- Simulation with historical data for 2020

A day-ahead market simulation tool called “Simulation facility” (SF) is available to many European TSOs. SF has access to all European historical day-ahead market data and uses the same algorithm as the SDAC – the Euphemia – to run day-ahead market simulations. The detailed description and methods of the Euphemia are given in [21] and are consistent with the theory given in Subchapter 1.4. SF gives its users a possibility to run simulations with historical or updated (user-defined) data or their combination and to get an updated market results from such simulations. For the purpose of this simulation, a collaboration with the Latvian TSO company *Augstsprieguma Tīkls* (AST) was initiated, and AST conducted a simulation in the SF using the historical power market data for the year 2020. The year 2020 was chosen as the most recent full year at the moment of conducting the simulation.

- Simulation set with forecasted data for 2030, 2040, and 2050

As the SF does only provide historic power market data and our task is to assess the SEW of LS scheme potentially to be installed in the nearest future, another alternative way of assessing the SEW for future scenarios has to be found. For this purpose, an existing market simulation environment recently created by the researchers of the Riga Technical University was utilized.

#### Introduction

A market simulation environment was developed specially for the case of the Baltic power system; it is based on three synthesized mathematical models in Matlab2020b software used to simulate the Baltic power system and its market and to calculate the SEW. The three mathematical models of the Baltic power system (BPS) and its market are: **Baltic Power System Basic (BPS\_B)** [39]–[41], **Baltic Power System Market Simplified (BPS\_MS)** , and **Baltic Power System Market Detailed (BPS\_MD)** [41] model.

#### Brief description of the BPS\_B mathematical model

The mathematical model of Baltic Power System Basic (BPS\_B) consists of several connected mathematical models, all developed in-house by the RTU Institute of Power Engineering. The BPS\_B model serves only as a topology basis for the market models BPS\_MS and BPS\_MD utilized in this simulation test case set.

#### Fundamental difference of applied BPS\_MS and BPS\_MD mathematical models

The models BPS\_MS and BPS\_MD are the mathematical models of the power market itself and are based on the power system topology model BPS\_B. The two created market models possess some fundamental differences, which are presented in Fig. 2.3. The presence of speculative opportunity is the main difference between the two developed models.



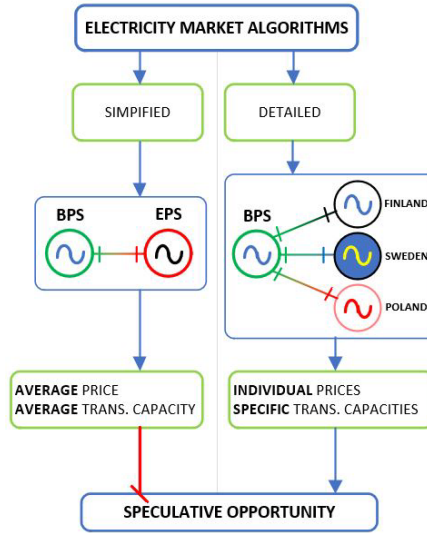

Fig. 2.3. Fundamental difference of two applied mathematical market models of BPS.

As seen in Fig. 2.3, the main difference of the “Detailed” model is the division of external power system into specific countries and an introduced speculative opportunity.

*Merit-order principle and generation/demand properties used in the simulation set*

While the Euphemia uses a full merit-order with all the possible generation types present, the market models in this simulation set use a simplified merit-order presented in Fig. 2.4.

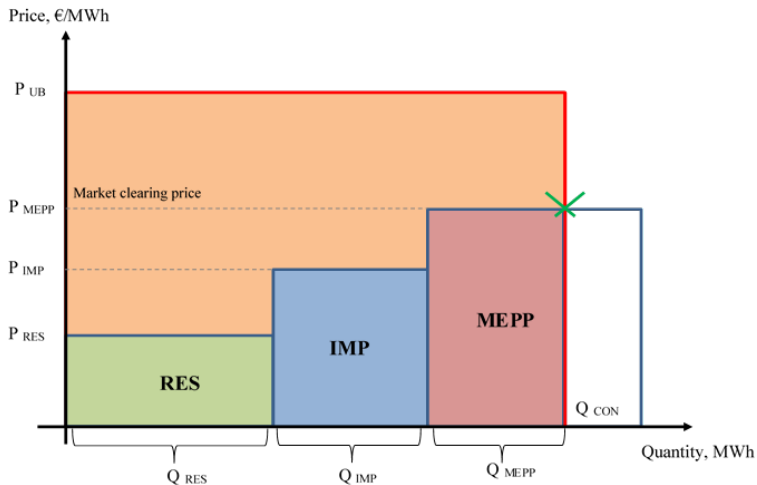

Fig. 2.4. Merit-order of the market models utilized for the simulation set.

The price forecasts for import areas are based on the historical power price data for the year 2019 [42]–[44] and on the forecast methods given in [45]. The forecasts were achieved the same

way the price forecasts in [40] were simulated. These can be found in Appendix I. The forecasts for RES production volumes were based on the statistics of meteorological data from [46]. The forecast of the long-term available capacity forecast of the MEPP in the Baltic region was based on t[47]–[52]. The demand model of the power system is simplified to represent a fully inelastic power demand given by its rectangular shape in Fig. 2.4. With all this information available, the method presented in [45] was used to achieve a reference price forecast for all of the scenarios of the upcoming simulation, similarly as this was done in [40].

When it comes to the surpluses needed to calculate the SEW, as stated in Subchapter 1.4, the producer surplus for these market models will be:

$$Surplus_{PROD} = P_{MEPP} \cdot Q_{CON} - (P_{RES} \cdot Q_{RES} + P_{IMP} \cdot Q_{IMP} + P_{MEPP} \cdot Q_{MEPP}). \quad (2.4)$$

The consumer surplus is:

$$Surplus_{CON} = P_{UB} \cdot Q_{CON} - P_{MEPP} \cdot Q_{CON} \quad (2.5)$$

And the SEW of the market is then as given by the theory in the Chapter 1.4:

$$SW = Surplus_{PROD} + Surplus_{CON}. \quad (2.6)$$

### 2.4.3. Practical usage of the calculated socio-economic welfare reduction and the congestion income

The reduction of socio-economic welfare for the power system between two different scenarios can be calculated using the following equation:

$$SWR_M = \frac{SW_{Y_{Sx}} - SW_{Y_{Sy}}}{8760} * T_{isl\_mode}, \quad (2.7)$$

where

$SWR_M$  – reduction of socio-economic welfare of the market, Eur);

$SW_{Y_{Sx}}$  – socio-economic welfare of the market (consisting of producers' and consumers' surpluses) for the whole year Y in scenario “x”, Eur;

$SW_{Y_{Sy}}$  – socio-economic welfare of the market (consisting of producers' and consumers' surpluses) for the whole year Y in scenario “y”, Eur;

$T_{isl\_mode}$  – total average duration of island mode operation during a year, h;

8760 – number of hours during a year, h.

### 3. MODELLING OF THE POWER SYSTEM WITH THE PROPOSED NOVEL LOAD SHEDDING SCHEME

In order to perform an assessment of the SEW gain of the proposed novel LS scheme, two sets of power grid dynamic simulation/test case studies will be executed based on two different Baltic power grid models derived from the models in [29] presenting a range of scenarios for the Baltic power system, using Siemens PSSE ver. 34 and ETAP ver. 12.5 [53], [54].

#### 3.1. Test case Set No. 1

The first test case study set will take a model of the Baltic power grid in island mode presented in [29] and enhanced by adding a set of synchronous condensers (SC); an overview of the system parameters in the different modelled scenarios is seen in Table 3.1

Table 3.1

Grid model parameters for different modelled scenarios, test case Set No.1, MW/MWs (in italics)

	Scenario			
	A	B	C	D
Total generation before disruption	2567	2548	2623	2686
of it renewable non-synchronous	100	700	1500	2500
Total load	3700	3700	3700	3700
Total import	1700	1700	1600	1530
Total export	500	500	500	500
Total post-contingency system inertia	<i>29.779</i>	<i>36.739</i>	<i>24.768</i>	<i>18.091</i>
$H_{tot\_post}$				
Gen. loss event	TEC2, 800 MW	HVDC, 700 MW	HVDC, 700 MW	HVDC, 700 MW

The scenarios from A to D gradually get the amount of non-synchronous RES increased and amount of system inertia decreased. A generator loss event is simulated and the frequency development studied. The summary of results of test case Set No. 1 can be seen in Table 3.2.

Table 3.2

Summary of results, test case Set No. 1.

	Scenario			
	A	B	C	D
$\Delta P_{SC}$ , MW	420	438	475	666
$P_{load\_UFLS}$ , MW	200	0	425.5	703
$P_{load\_UFLS}$ , % of total load	5.4	0	11.5	19
$P_{load\_novel\_LS}$ , MW	200	200	425.5	703
Frequency nadir when UFLS does not activate (scenario B), Hz	-	48.81	-	-
Frequency nadir conventional UFLS, Hz	48.7	-	48.6	48.3
Frequency nadir novel LS method, Hz	48.85	49.1	49.15	49.6

### 3.2. Test case Set No. 2

The second test case study set is also based on another model previously presented in [29]. The model has a more detailed depiction of Latvian power system depicting Estonian and Lithuanian power systems as grid equivalents – thus providing a different dynamic response to disturbances than the model in the test case Set No. 1. An overview of the test case set scenario parameters in the different modelled scenarios is seen in Table 3.3.

Table 3.3

Grid element parameters for different modelled scenarios, test case Set No. 2, MW/MWs (in italics)

Scenario	CHP2	HPP	EE	LT	WTG2	WTG4	WTG6	WTG10	Gen. Loss Event	Total System Inertia
A	800	220	670	380	128	40	120	-	EE	<i>15.760</i>
B	-	800	990	400	128	40	120	-	HPP	<i>12.150</i>
C	800	-	50	350	128	40	120	640	CHP2	<i>12.148</i>

Three scenarios (A–C) were simulated using ETAP 12.5 electrical software [54]. The goal of simulation was to explore the system frequency response under various loss-of-generation events. Total load of the Latvian grid is assumed to be ca. 2400 MW for all cases. Approximately half of the consumption is covered by in-house generation capacity with the remaining power imported from EE and LT. The loss-of-generation events were simulated by disconnecting one of the major generation sources. The simulation results for all scenarios of the test case Set No. 2 are given in Table 3.4.

Table 3.4

Summary of results, test case Set No. 2

Scenario	$\Delta P_{gen, loss}$ , MW	$\Delta P_{load, UFLS}$ , MW	Conventional UFLS $f_{min}$ , Hz	$\Delta P_{sc}$ , MW	Novel Approach LS with K = 1 + Additional Load Shed by Conv. UFLS		Novel Approach LS with K=2 + Additional Load Shed by Conv. UFLS		Novel Approach LS with K=3 + Additional Load Shed by Conv. UFLS	
					$f_{min}$ , Hz	Add. Conv. UFLS, MW	$f_{min}$ , Hz	Add. Conv. UFLS, MW	$f_{min}$ , Hz	Add. Conv. UFLS, MW
					A	670	120	48.9	150	49.06
B	800	960	48.1	280	48.4	480	48.72	240	49.48	-
C	800	480	48.45	330	48.9	120	N/A	-	N/A	-

### 3.3. Results

Simulation results show a substantial improvement of frequency stability with the proposed LS scheme bringing the frequency around or over the critical threshold of 49 Hz in the most cases.

## 4. SOCIO-ECONOMIC ASSESSMENT OF THE EFFECT OF THE PROPOSED NOVEL LOAD SHEDDING SCHEME. HISTORICAL INPUT DATA.

### 4.1. General info and definition of study case scenarios

The case study assesses an economic impact of the proposed LS scheme using Baltic states as a study subject and by using the historical Baltic power system and power market data for 2020. For the purpose of the case study, Latvian TSO company *Augstsprieguma Tīkls* (AST) on the formal request of the author has performed simulations in the SF and formally provided results already in processed and combined form. Simulations have been performed for three scenarios described below. The main goal is to assess the SEW differences between the reference scenario and the scenarios with transmission capacity restrictions.

Scenario 1. The reference case. Using historical data on transmission capacities on all the borders except the Latvia–Russia and Lithuania–Belarus borders, where 0 (zero) MW cross-zonal capacity has been used (these particular borders are not relevant for the post-2025 situation).

Scenario 2. The maximum capacities of HVDC links of the Finland–Estonia (only applicable to Estlink 2 capacity), Sweden–Lithuania, and Poland–Lithuania borders have been reduced 50 MW below the nominal (maximum) capacity. In case if historical capacity on the border for exact simulation hour has been already below “nominal capacity”, historical value has not been changed. 0 (zero) MW cross-zonal capacity has been used on the Latvia–Russia and Lithuania–Belarus borders.

Scenario 3. The maximum capacities of HVDC links of the Finland–Estonia (only applicable to Estlink 2 capacity), Sweden–Lithuania, and Poland–Lithuania borders have been reduced to the level of 400 MW. This scenario is the most realistic scenario for the post-2025 situation expected for the Baltic power system when operating in an island mode [17]. In case if historical capacity on the border for exact simulation hour has been already below 400 MW, historical value has not been changed. 0 (zero) MW cross-zonal capacity has been used on the Latvia–Russia and Lithuania–Belarus borders. This scenario corresponds to the expected behavior of the Baltic TSOs during island mode of operation of the post-2025 situation described in Subchapter 2.3.

The case study uses the exact same load disconnection scenarios from [12] or observed in Table 3.2 – 200MW, 425.5MW, and 702MW of load disconnected by the proposed novel LS scheme; the loads are assumed disconnected for 0.5 h, as this is a maximal time for reserve activation and a normalization of the situation following a major frequency disturbance [17]. Both market limitation scenarios – Scenarios 2 and 3 are used as described in this subchapter. The simulation parameter and the resulting case study number overview is presented in Table 4.1.

Table 4.1

## SEW with historical data simulation parameter overview

Load disconnected / energy not served due to the LS scheme, MW/MWh	Scenario	Case study
200/100	Scenario 2	1.A
	Scenario 3	1.B
425.5/212.75	Scenario 2	2.A
	Scenario 3	2.B
703/351.5	Scenario 2	3.A
	Scenario 3	3.B

## 4.2. Results

The obtained case study simulation results were transformed into practical market social welfare reduction  $SWR_M$ , costs of the reserves  $SWR_R$ , congestion income  $CI$ , and load shedding costs  $LSC$  values. These are presented in Table 4.2.

Table 4.2

## Final economic analysis results for the case study

Case study	$SWR_M$ , MEUR/year	$CI$ , MEUR/year	$SWR_R$ , MEUR/year	$SWR_{total}$ , MEUR/year	$LSC$ , MEUR/year
1.A	3.29	-0.005	0.055	<b>3.340</b>	<b>0.040</b>
1.B	11.10	-0.039	0.314	<b>11.375</b>	
2.A	3.29	-0.005	0.055	<b>3.340</b>	<b>0.080</b>
2.B	11.10	-0.039	0.314	<b>11.375</b>	
3.A	3.29	-0.005	0.055	<b>3.340</b>	<b>0.130</b>
3.B	11.10	-0.039	0.314	<b>11.375</b>	

The results show that the total reduction of SEW for all scenarios compared to the base case is substantial. The costs of the reserve activation due to the reduction of the cross-border capacities are found to be relatively small, the same is the case for load shedding costs, LSC. As it is Scenario 3, which holds a practical importance, a conclusion can be made that total savings due to a potential introduction of the proposed novel LS scheme in the Baltics will be in the range of 11.2–11.3 MEUR.

## 5. SOCIO-ECONOMIC ASSESSMENT OF THE EFFECT OF THE PROPOSED NOVEL LOAD SHEDDING SCHEME. FORECASTED INPUT DATA.

### 5.1. General info and definition of study case scenarios

The case study assesses an economic impact of the proposed LS scheme using the Baltic states as a study subject and by using the forecasted input data for the Baltic power system and power market data for 2030, 2040, and for 2050 (two cases).

Table 5.1 shows the simulation set parameters for the power generation sources and the power demand for the four scenario target year groups. The two 2050-cases differ by the amount of the RES present in the scenarios.

Table 5.1

Basic parameters of modelling scenarios

	Parameter	Load/power consumption	SPP	WPP	HPP	sHPP	BPP	PSHPP	MEPP
Scenario	2030								
	Max capacity, MWh/h	6 026	1 489	3 907	1 562	165	522	1 625	4 330
	Annual power demand/supply, TWh	37.86	1.74	11.66	1.90	0.34	3.52	2.85	n/a
Scenario	2040								
	Max capacity, MWh/h	6 629	1 608	4 994	1 562	165	522	1 625	1 500
	Annual power demand/supply, TWh	39.83	1.88	14.90	1.90	0.34	3.52	2.85	n/a
Scenario	2050 1								
	Max capacity, MWh/h	7 233	2 383	7 127	1 562	165	522	1 625	1 500
	Annual power demand/supply, TWh	41.80	2.78	21.26	1.90	0.34	3.52	2.85	n/a
Scenario	2050 2								
	Max capacity, MWh/h	7 233	3 872	11 586	1 562	165	522	1 625	1 500
	Annual power demand/supply, TWh	41.80	4.52	34.57	1.90	0.34	3.52	2.85	n/a

A scenario envelope was defined for this simulation process based on already mentioned different forecast target years, different MEPP generation prices (low/high) and simulation

model complexity (BPS\_MS and BPS\_MD. The simulation scenario envelope and the resulting case study number overview is presented in Table 5.2.

Table 5.2

Simulation parameter overview

Target year	MEPP level (low/high)	Simulation model complexity	Case study
2030	L	Simplified	4
		Detailed	5
	H	Simplified	6
		Detailed	7
2040	L	Simplified	8
		Detailed	9
	H	Simplified	10
		Detailed	11
2050_1	L	Simplified	12
		Detailed	13
	H	Simplified	14
		Detailed	15
2050_2	L	Simplified	16
		Detailed	17
	H	Simplified	18
		Detailed	19

The overview of transmission capacity restriction parameters for the scenarios can be seen in Table 5.3.

Table 5.3

Transmission capacity restriction parameters for the simulation set

Transmission capacity restriction (no/yes)	Transmission line capacity, MWh/h		
	EE ↔ FI	LT ↔ SE4	LT ↔ PL
n	1 016	700	700
y	750	400	400

## 5.2. Results

The obtained case study simulation results were transformed into practical market social welfare reduction  $SWR_M$ , costs of the reserves  $SWR_R$ , and load shedding costs LSC values. These are presented in Table 5.4.



Table 5.4

## Final economic analysis results for the case study

Case study	$SWR_M$ , MEUR/year	$SWR_R$ , MEUR/year	$SWR_{total}$ , MEUR/year	$LSC$ , MEUR/year
<b>4</b>	1.14	0.44	<b>1.58</b>	<b>0.13</b>
<b>5</b>	1.20	0.51	<b>1.71</b>	
<b>6</b>	3.04	0.87	<b>3.91</b>	
<b>7</b>	3.10	1.02	<b>4.12</b>	
<b>8</b>	0.29	0.41	<b>0.70</b>	
<b>9</b>	0.36	0.49	<b>0.85</b>	
<b>10</b>	1.28	0.81	<b>2.09</b>	
<b>11</b>	1.35	0.97	<b>2.32</b>	
<b>12</b>	0.10	0.33	<b>0.43</b>	
<b>13</b>	0.18	0.42	<b>0.60</b>	
<b>14</b>	0.80	0.70	<b>1.50</b>	
<b>15</b>	0.88	0.83	<b>1.71</b>	
<b>16</b>	0.14	0.21	<b>0.35</b>	
<b>17</b>	0.20	0.31	<b>0.51</b>	
<b>18</b>	0.66	0.43	<b>1.09</b>	
<b>19</b>	0.70	0.61	<b>1.31</b>	

The results show that for all case studies in the simulation set, the total SEW sees a reduction when compared to the base case. For some of the case studies this reduction is relatively low and for some it reaches million EUR magnitude. The costs of the reserve activation,  $SWR_R$ , for this simulation set are found to comprise a substantial part of the overall SEW reduction.

The same way as for the previous simulation set, the costs for LSC – the costs related to the disconnection of the consumers due to the activation of the novel LS scheme – are for all case studies lower than the total SEW reduction.

A conclusion can be made that total savings due to a potential introduction of the proposed novel LS scheme in the Baltics will be in the range of 0.35–4.12 MEUR.

## CONCLUSIONS

1. The hypothesis of the Thesis has been proven and the objective has been achieved. The proposed novel LS scheme, based on the usage of SC as a frequency sensor, does substantially improve the frequency stability and increases the SEW of a weakly interconnected or a low-inertia power system. The whole range of case studies carried out during the Thesis research has proven those statements.
2. The tasks of the Thesis have been successfully carried out:
  - A theoretical background and motivation for introduction of the proposed novel LS scheme were explained. An explanation on the fundamental novelty of the proposal – usage of SC as ROCOF sensors – was given and advocated. Further, the detailed methods and concepts for the proposed LS scheme were introduced.
  - A grid-stability related motivation for an introduction of the proposed LS scheme was given.
  - An economic/fiscal motivation for an introduction of the proposed LS scheme was given.
3. A series of case studies/simulations to measure the effect of the proposed LS scheme on power system stability were conducted. The case studies showed in unison a major positive effect of the proposed LS scheme on the frequency stability of the given power system when comparing to the present UFLS schemes. The proposed LS scheme showed an ability to limit power system frequency fall in cases of major loss-of-generation contingencies and hold the frequency above the dangerous blackout threshold of 49 Hz. The detected positive effect of the proposed LS scheme had a strong direct correlation with decreasing power system inertia levels.
4. A series of case studies/simulations to measure the effect of the proposed LS scheme on power systems SEW were conducted. The case studies showed positive effect of the proposed LS scheme on the SEW of the Baltic power system operating in an island mode after their desynchronization from the UPS/IPS grid when comparing to the situation when the scheme is not introduced. The measured positive effect on the SEW is in the magnitude of millions of EUR for most of the studied scenarios. The detected measured positive effect on the SEW had a strong direct correlation with increased power imports into the Baltic power system.

## REFERENCES

- [1] UN Framework Convention on Climate Change, *The Paris Agreement*, 2016.
- [2] International Renewable Energy Agency, "World Energy Transitions Outlook – 1.5 °C Pathway, Preview", 2021.
- [3] International Energy Agency, "Seven Key Principles for Implementing Net Zero", 2021.
- [4] ENTSO-E, "TYNDP 2020 – Completing the map. Power system needs in 2030 and 2040", ENTSO-E, Brussels, 2021.
- [5] ENTSO-E, "Nordic report – Future system inertia", ENTSO-E, Brussels, 2018.
- [6] European Commission, *Energy security: The synchronisation of the Baltic States' electricity networks – European solidarity in action; press release*, Brussels, Belgium, 2019.
- [7] H. T. Nguyen, G. Yang, A. H. Nielsen, P. Højgaard Jensen, "Combination of Synchronous Condenser and Synthetic Inertia for Frequency Stability Enhancement in Low-Inertia Systems", *IEEE Transactions on sustainable energy*, vol. 10, iss. 3, 2019.
- [8] A. Stiger, R. A. Rivas, M. Halonen, "Synchronous Condensers Contribution to Inertia and Short Circuit Current in Cooperation with STATCOM", *2019 IEEE PES GTD Grand International Conference and Exposition Asia (GTD Asia)*, Bangkok, Thailand, 2019.
- [9] R. W. Kenyon, A. Hoke, J. Tan, B. Kroposki, B.-M. Hodge, "Grid-Following Inverters", *2020 Clemson University Power Systems Conference*, Clemson, USA, 2020.
- [10] M. Nedd, C. Booth, K. Bell, "Potential solutions to the challenges of low inertia power systems with a case study concerning synchronous condensers", *52nd International Universities Power Engineering Conference (UPEC)*, Heraklion, Greece, 2017.
- [11] J. Machowski, J. W. Bialek, J. R. Bumby, *Power System Dynamics*, 2 red., John Wiley & Sons, 2008, p. 171.
- [12] A. Sauhats, A. Utans, J. Silinevics, G. Junghans, D. Guzs, "Enhancing Power System Frequency with a Novel Load Shedding Method Including Monitoring of Synchronous Condensers' Power Injections", *Energies*, vol. 14, iss. 5, 2021.
- [13] DNV GL, "RoCoF Alternative Solutions Technology Assessment – Final report phase 1", 2015.
- [14] C. Payerl, "Introduction to ABB Synchronous Condenser offering – A solution to improve grid strength", 2020. [Website]. Available: [https://library.e.abb.com/public/1fb2ec9a1eb34241924f030f47048951/Syncon\\_webinar\\_2020\\_Dec\\_presented\\_2020DEC.pdf](https://library.e.abb.com/public/1fb2ec9a1eb34241924f030f47048951/Syncon_webinar_2020_Dec_presented_2020DEC.pdf). [Accessed 24 July 2022].
- [15] A. Moser, *Planung und Betrieb von Elektrizitätsversorgungssystemen, Skriptum zur Vorlesung*, Aachen: IAEW, 2012, pp. 151–153.
- [16] W. Huang, J. Yu, Z. Yuan, Z. He, J. He un M. Deng, «An adaptive under-frequency optimal control strategy for power system combined pumped storage and under-frequency load shedding.,» *PLOS ONE*, vol. 16, iss. 12, 2021.
- [17] AS Augstsprieguma Tikls, Personal communication, Riga, Latvia, 2020.
- [18] ACER, «Study on the estimation of the value of lost load of Electricity supply in Europe. Final report.,» ACER, Brussels, 2018.
- [19] L. Hirth, «The Merit Order Model and Marginal,» 2 September 2022. [Website]. Available: <https://neon.energy/marginal-pricing>. [Accessed 19 February 2023].
- [20] ENTSO-E, "2nd ENTSO-E Guideline For Cost Benefit Analysis of Grid Development Projects", 2018.

- [21] NordPoolSpot, "EUPHEMIA Public Description", [Website]. Available: <https://www.nordpoolgroup.com/globalassets/download-center/single-day-ahead-coupling/euphemia-public-description.pdf>. [Accessed 24 August 2022].
- [22] N-Side, "Public presentation of Euphemia description and functioning", [Website]. Available: <https://www.n-side.com/wp-content/uploads/2017/08/Euphemia-Public-Presentation.pdf>. [Accessed 23 May 2021].
- [23] European Commission, "The Baltic Power System Between East and West Interconnections, JRC Science for Policy Report", Brussels, Belgium, 2016.
- [24] NordPoolSpot, [Website]. Available: <https://www.nordpoolgroup.com>. [Accessed 15 December 2020].
- [25] G. Junghans, A. Silis, K. Marcina, K. Ertmanis, "Role of Balancing Markets in Dealing with Future Challenges of System Adequacy Caused by Energy Transmission", *Latv. J. Phys. Tech. Sci.*, vol. 57, p. 48–56, 2020.
- [26] European Union, "2030 Climate & Energy Framework", Brussels, Belgium, 2020.
- [27] AS Augstspriegum Tikls, "MK DOD ZAĻO GAISMU AST IEGĀDĀTĪES, PĀRVALDĪTUN EKSPLUATĒT ELEKTROENERĢIJAS AKUMULĀCIJASIEKĀRTAS JEB BATERIJAS", [Website]. Available: <https://www.ast.lv/lv/events/mk-dod-zalo-gaismu-ast-iegadaties-parvaldit-un-ekspluatet-elektroenerģijas-akumulācijas>. [Accessed 23 February 2023].
- [28] S. Kiene, O. Linkevics, K. Gicevskis, E. Groza, "Modelling of Battery Energy Storage System Providing FCR in Baltic Power System after Synchronization with the Continental Synchronous Area", *Energies*, vol. 15, iss. 11.
- [29] D. Guzs, A. Utans, A. Sauhats, G. Junghans, J. Silinevics, "Resilience of the Baltic power system when operating in island mode", *IEEE 61th International Scientific Conference on Power and Electrical Engineering of Riga Technical University (RTUCON)*, Riga, Latvia, 2020.
- [30] A. Rubio, H. Behrends, S. Geissendorfer, K. von Maydell, C. Agert, "Determination of the Required Power Response of Inverters to Provide Fast Frequency Support in Power Systems with Low Synchronous Inertia", *Energies*, vol. 13, iss. 816, 2020.
- [31] I. B. Sperstad, O. Wolfgang, T. I. Reigstad, G. H. Kjolle, "Probabilistic socio-economic cost assessment integrating power market and reliability analysis", *IEEE International Conference on Probabilistic Methods Applied to Power Systems (PMAPS)*, Boise, ID, USA, 2018.
- [32] L. Wenyuan, RISK ASSESSMENT OF POWER SYSTEMS. Models, Methods, and Applications, JOHN WILEY & SONS INC, 2014.
- [33] A. A. Chowdhury, D. O. Koval, "Deregulated Transmission System Reliability Planning Criteria Based on Historical Equipment Performance Data", *IEEE Transactions on industry applications*, vol. 37, iss. 1, 2001.
- [34] A. A. Chowdhury, D. O. Koval, "Assessment of Transmission-Line Common-Mode, Station-Originated, and Fault-Type Forced-Outage Rates", *IEEE Transactions on industry applications*, vol. 46, iss. 1, 2010.
- [35] Ю. Н. Балаков, М. Ш. Мисриханов, А. В. Шунтов, Проектирование схем электроустановок, ЗАО "Издательский дом МЭИ", 2004.
- [36] Е. Н. Ефимов, Л. В. Тимашова, Н. В. Ясинская, "ПРИЧИНЫ И ХАРАКТЕР ПОВРЕЖДАЕМОСТИ КОМПОНЕНТОВ ВОЗДУШНЫХ ЛИНИЙ ЭЛЕКТРОПЕРЕДАЧИ НАПРЯЖЕНИЕМ 110–750 кВ В 1997–2007 ГГ.", *ЭНЕРГИЯ ЕДИНОЙ СЕТИ*, vol. 5, iss. 5, 2012.
- [37] ENTSO-E AISBL, "Nordic and Baltic Grid Disturbance Statistics 2019. Regional Group Nordic", 22 September 2020. [Website]. Available: <https://eepublicdownloads.blob.core.windows.net/public-cdn-container/clean->

documents/Publications/SOC/Nordic/Nordic\_and\_Baltic\_Grid\_Disturbance\_Statistics\_2018.pdf. [Accessed 13 July 2021].

- [38] NordPoolSpot, "Urgent Market Messages (UMM)" [Website]. Available: <https://umm.nordpoolgroup.com/>. [Accessed 25 August 2022].
- [39] R. Petrichenko, J. Kozadajevs, L. Petrichenko, A. Silis, "Reserve power estimation according to the Baltic power system 2050 development plan" *2022 IEEE 7th International Energy Conference (ENERGYCON)*, 2022.
- [40] R. Petrichenko, A. Sauhats, K. Baltputnis, Z. Broka, L. Petrichenko, "Modelling the Future of the Baltic Energy Systems: A Green Scenario" *Latvian Journal of Physics and Technological Sciences*, vol. 58, iss. 3, pp. 47–65, 2021.
- [41] R. Petrichenko, L. Petrichenko, O. Ozgonenel, R. Komarovs, "The assessment of long-term import-export capabilities of Baltic power system" *IEEE 62nd International Scientific Conference on Power and Electrical Engineering (RTUCON)*, 2021.
- [42] ENTSO-E, "Transparency platform" [Website]. Available: <https://transparency.entsoe.eu/transmission-domain/r2/dayAheadPrices/show>. [Accessed 19 February 2023].
- [43] SKM Market Predictor AS, "Long-Term Power Outlook 2019" [Website]. Available: <https://www.skmenergy.com/reports/long-term-power-outlook>.
- [44] Nord Pool AS, "Day-ahead market", [Website]. Available: <https://www.nordpoolgroup.com/the-power-market/Day-ahead-market>.
- [45] L. Petrichenko, A. Sauhats, R. Petrichenko, D. Bezrukovs, "Long-Term Price Forecasting for the Cost-Benefit Analysis of Power Equipment", 2018 IEEE 59th International Scientific Conference on Power and Electrical Engineering of Riga Technical University (RTUCON), Riga, Latvia, 2018.
- [46] LVGMC, LVGMC, Latvian Environment, Geology and Meteorology Centre", [Website]. Available: <https://videscentrs.lvgmc.lv/>.
- [47] Litgrid AB, "Scenario Building for the Evolution of Lithuanian Power Sector for 2020– 2050", [Website]. Available: [https://lsta.lt/wp-content/uploads/2020/12/201217-Scenario-building-for-Lithuanian-electric-power-sector\\_final-report.pdf](https://lsta.lt/wp-content/uploads/2020/12/201217-Scenario-building-for-Lithuanian-electric-power-sector_final-report.pdf).
- [48] M. Neeme, "The future of the Estonian energy sector in relation to EU 2050 low carbon economy roadmap", [Website]. Available: [https://stud.epsilon.slu.se/9368/1/neeme\\_m\\_160706.pdf](https://stud.epsilon.slu.se/9368/1/neeme_m_160706.pdf).
- [49] Estonian Parliament, "Resolution of the Riigikogu. General Principles of Climate Policy until 2050", [Website]. Available: [https://ec.europa.eu/clima/sites/lts/lts\\_ee\\_et.pdf](https://ec.europa.eu/clima/sites/lts/lts_ee_et.pdf).
- [50] Republic of Estonia, "Estonia's 2030 National Energy and Climate Plan (NECP 2030)", [Website]. Available: <https://faolex.fao.org/docs/pdf/est200007.pdf>.
- [51] European Commission, "European Commission, 2050 long-term strategy", [Website]. Available: [https://ec.europa.eu/clima/policies/strategies/2050\\_en#tab-0-0](https://ec.europa.eu/clima/policies/strategies/2050_en#tab-0-0).
- [52] The Republic of Latvia, "Strategy of Latvia for the Achievement of Climate Neutrality by 2050", [Website]. Available: [https://ec.europa.eu/clima/sites/lts/lts\\_lv\\_en.pdf](https://ec.europa.eu/clima/sites/lts/lts_lv_en.pdf).
- [53] Siemens Power Technologies Inc., *PSS/E-34 Program Operational Manual*, New York, NY, USA, 2019.
- [54] Operation Technology Inc., *ETAP Products & Solutions Comprehensive, Integrated Suite of Power System Software Modules from Design to Operation*, Irvine, CA, USA, 1995.



**Dmitrijs Guzs** was born in 1985 in Jelgava, Latvia. He received a Master's degree in Energy Physics from the Norwegian University of Life Sciences in 2009 and a Master's degree in Electrical Power Engineering from RWTH Aachen in 2014. He has been employed at "Statkraft Energi AS", "Bayer Technology Services GmbH", and "AS Augstsprieguma Tīkls". Since 2022, he has been a senior engineer in the Baltic RCC. His scientific interests are power system frequency stability, load shedding schemes and power system socioeconomic welfare calculations.